

E-Z TRENCH®

Bedscaper™

BE310

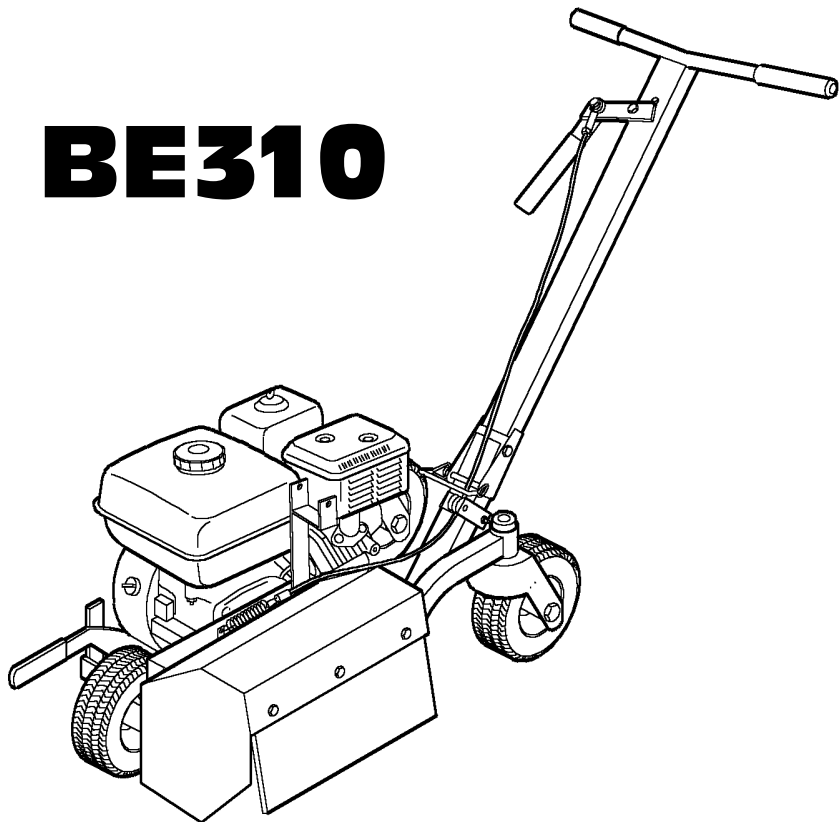

Owners Manual

E-Z Trench Manufacturing Co., Inc.

2315 S. Hwy. 701 • Loris, S.C. 29569

(843) 756-6444

Fax (843) 756-6442

www.eztrench.com

A WORD TO E-Z TRENCH OWNERS . . .

THIS MANUAL HAS BEEN PREPARED TO ACQUAINT YOU WITH THE ASSEMBLY, OPERATION AND MAINTENANCE OF YOUR BE310 TRENCHING MACHINE, AND TO PROVIDE SAFETY INFORMATION. WE URGE YOU TO READ IT CAREFULLY AND FOLLOW THE RECOMMENDATIONS CONTAINED TO HELP ASSURE THE MOST TROUBLE-FREE OPERATION.

WE WOULD LIKE TO TAKE THIS OPPORTUNITY TO THANK YOU FOR CHOOSING E-Z TRENCH, AND TO ASSURE YOU OF OUR CONTINUING INTEREST IN YOUR NEEDS.

INDEX

1. A WORD TO E-Z TRENCH OWNERS
2. WARNING & SAFETY PRECAUTIONS / OPERATING INSTRUCTIONS
3. TROUBLE SHOOTING / MAINTENANCE SCHEDULE
- 4.-5. PARTS DRAWING / PARTS LIST
- 6.-7. TERMS & CONDITIONS OF SALE
8. MAINTENANCE GRID

WARNINGS! & SAFETY PRECAUTIONS

1. KEEP HANDS AND FEET CLEAR OF HIGH SPEED DIGGING BLADE.
2. NEVER MANUALLY ROTATE BLADE WHEN ENGINE IS IN "ON" POSITION.
3. ALWAYS WEAR EYE PROTECTION.
4. KEEP HANDS AND FEET CLEAR OF PULLEYS AND BELTS WHEN ENGINE IS RUNNING.
5. CLEAR TRENCHING PATH OF ANY DEBRIS OR TOOLS.
6. LOCATE ALL UNDERGROUND POWER, TELEPHONE, GAS AND WATER LINES BEFORE TRENCHING.
7. ENGINE R.P.M. SHOULD RUN AT 3600 R.P.M.

OPERATING INSTRUCTIONS

1. FILL CRANKCASE OF ENGINE AND CLUTCH WITH OIL. FOLLOW INSTRUCTIONS OF ENGINE MANUFACTURER.
2. MOVE FRONT WHEEL CARRIAGE (BE326) TO OPERATING POSITION BY PUSHING OR PULLING DEPTH ADJUSTMENT RELEASE (BE323) AND PULLING UP ON THE FRONT WHEEL CARRIAGE'S HANDLE.
3. START ENGINE.
4. PRESS DOWN ON HANDLE BARS SLIGHTLY TO RAISE BLADE CLEAR OF GROUND.
5. SQUEEZE THROTTLE LEVER ON HANDLE BAR TO START BLADE.
6. SLOWLY LOWER BLADE INTO SOIL UNTIL FRONT WHEEL IS ON THE GROUND.
8. VERIFY THAT YOUR TRENCHING PATH IS CLEAR AND PROCEED TO PULL GENTLY TO BEGIN TRENCHING.
8. TO CREATE CURVED BEDS SIMPLY PULL THE **BEDSCAPER™ MODEL BE310** IN THE DIRECTION YOU WANT IT TO GO. GUIDE THE LEFT REAR TIRE ALONG EXISTING BED EDGES TO REDEFINE THEM.
9. WHEN YOU ARE FINISHED TRENCHING TURN ENGINE OFF.
10. MOVE FRONT WHEEL CARRIAGE TO TRAVELING POSITION BY REVERSING STEP 2.

TROUBLE SHOOTING

PROBLEM	SOLUTION
IRREGULAR OR EXCESSIVE BELT WEAR	<ol style="list-style-type: none"> 1. CHECK FOR PULLEY MISALIGNMENT. 2. USE OF OTHER THAN FACTORY POWER-RATED BELTS. 3. RATE OF DIG IS TOO FAST FOR SOIL CONDITION.
EXCESSIVE VIBRATION	<ol style="list-style-type: none"> 1. LOOSE, BENT, OR BROKEN BLADE OR BIT. 2. LOOSE ENGINE MOUNT BOLTS. 3. ENGINE R.P.M. SHOULD BE 3600 R.P.M.
HOUSING CLOGGING WITH DIRT	<ol style="list-style-type: none"> 1. SOIL IS TOO WET. 2. FOREIGN OBJECT IN HOUSING.
BENT OR BROKEN DIGGING BLADE	<ol style="list-style-type: none"> 1. STRIKING HARD OBJECTS, SUCH AS BRICKS, LARGE ROCKS, AND STEEL OBJECTS.

MAINTENANCE SCHEDULE

Perform at every indicated month or operating hour interval, whichever comes first.	Every Use	First month or 20 Hrs.	Every 3 months or 50 Hrs.	Every 6 months or 100 Hrs.
Check blade and bits	<input type="radio"/>			
Check engine oil & air filter	<input type="radio"/>			
Lubricate pivot points after washing	<input type="radio"/>			
Tighten any loose bolts		<input type="radio"/>		
Change engine oil*		<input type="radio"/>	<input type="radio"/>	
Check air pressure of tires			<input type="radio"/>	
Clean air filter or replace			<input type="radio"/>	
Change clutch oil**		<input type="radio"/>	<input type="radio"/>	

*Break in engine with petroleum based oil, then switch to E-Z Trench™ specially formulated synthetic.

**Use only E-Z Trench™ synthetic for high wear resistance and reduced heat. (Part #EZ10W30)

E-Z-TRENCH®

843-756-6444

BEDSCAPER™ BE310 PARTS LIST

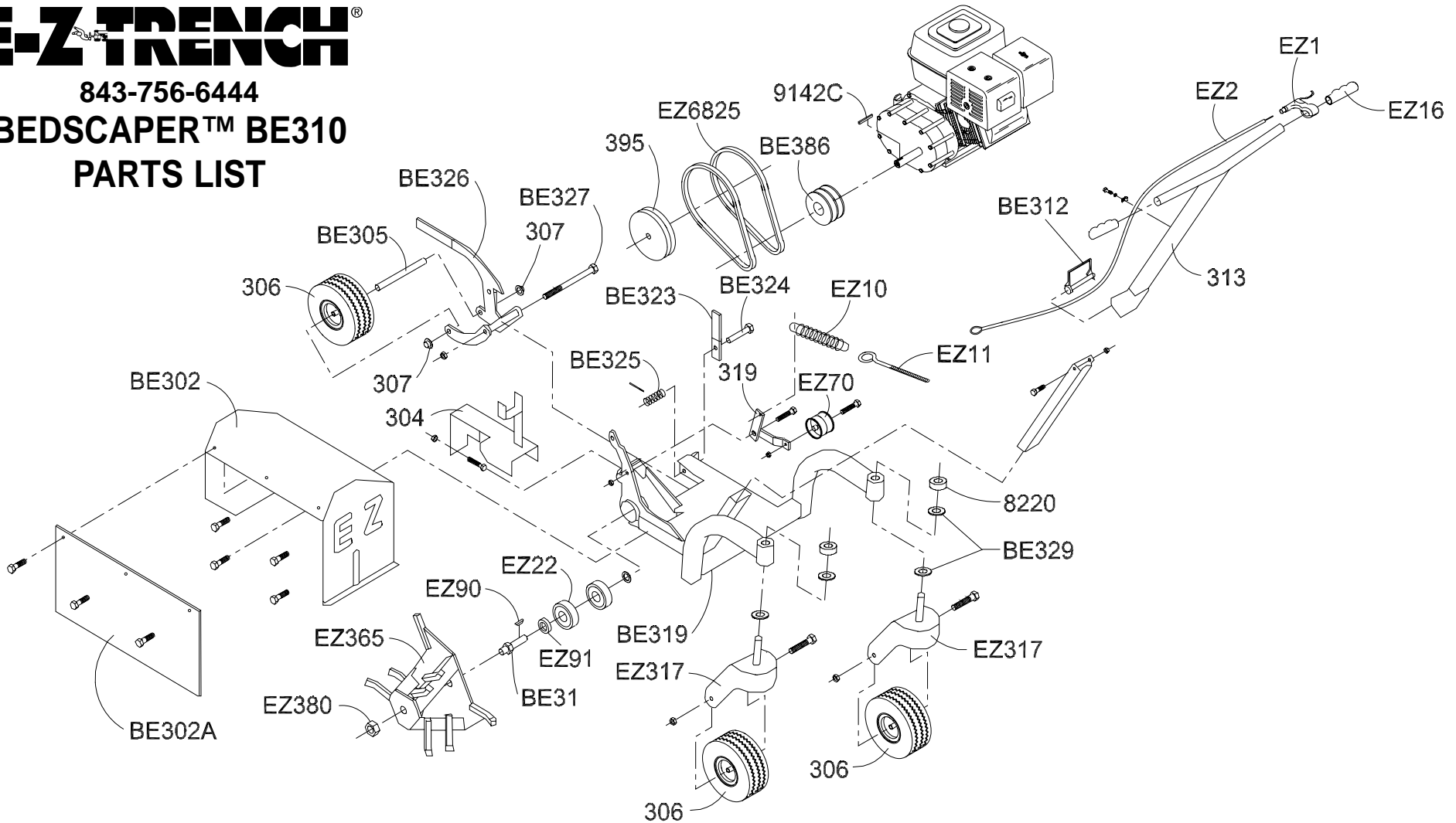

PART #	DESCRIPTION
304	ENGINE BRACKET/BELT GUARD
306	PNEUMATIC TIRE
307	PUSH CAP
313	HANDLEBAR
319	BELT TENSION IDLER
395	4" BLADE PULLEY
8220	CASTER LOCK CAP
9142C	DRIVE SHAFT KEY
BE302	HOOD
BE305	FRONT AXLE
BE311	OUTPUT SHAFT

4.

PART #	DESCRIPTION
BE312	HANDLE LOCK PIN
BE319	FRAME
BE323	DEPTH ADJUSTMENT RELEASE
BE324	DEPTH ADJUSTMENT RLS PIN
BE325	DEPTH ADJUSTMENT RLS SPRING
BE326	FRONT WHEEL CARRIAGE
BE327	WHEEL CARRIAGE BOLT
BE329	CASTER BUSHING SHIMS
BE386	3" ENGINE PULLEY
EZ1	THROTTLE
EZ2	THROTTLE CABLE

PART #	DESCRIPTION
EZ10	BELT TENSION SPRING
EZ11	TENSION EYE BOLT
EZ16	HANDLEBAR GRIPS
EZ22	SEALED BEARING
EZ70	IDLER PULLEY
EZ90	WOODRUFF KEY (HALF MOON)
EZ91	LOCK COLLAR
EZ317	CASTER
EZ365	LANDSCAPE BLADE
EZ380	3/4" NUT
EZ6825	1/2" X 25" POWERATED BELT

5.

TERMS AND CONDITIONS OF SALE

USE:

E-Z TRENCHER IS DESIGNED TO TRENCH IN SOIL ONLY. ANY OTHER USE IS AT THE RISK OF THE OWNER.

PRICES:

Prices are subject to change without notice and will be invoiced at prices in effect on date of order.

CHANGES:

E-Z TRENCH MANUFACTURING, Inc. reserves the right to discontinue items, change specification, design, or prices at any time, without notice and without incurring any obligation whatsoever.

FREIGHT POLICY:

All orders are F.O.B., Loris, South Carolina, USA. Title to goods and risk of loss passed in Loris, South Carolina.

DAMAGED OR LOST SHIPMENTS:

All shipments must be carefully inspected. In case of damaged or loss, accept the shipment, but have carrier note damages or loss on delivery receipt. If it is concealed damage, call carrier for inspection. Make claim for damage with carrier.

LIMITED WARRANTY:

The E-Z Trencher is warranted against defects in workmanship or materials for a period of one year. Blades, bits, belts and bearings, which are normal wear items, are not warranted. This warranty covers replacement of parts only, no consequential damages are covered. In the event of a warranty claim contact E-Z Trench Manufacturing Company, Inc. This warranty does not include products which have been subject to improper use, or application, or misuse, neglect or accident; nor does it attend to products which have been repaired or altered by other than E-Z Trench Manufacturing Company, Inc. All warranty repairs are F.O.B., Loris, S.C, U.S.A. E-Z Trench Manufacturing Company, Inc. will not be responsible for any transportation charges.

THERE IS NO OTHER EXPRESS WARRANTY. TO THE EXTENT PERMITTED BY LAW ALL IMPLIED WARRANTIES INCLUDED THOSE OF MERCHANTABILITY AND FITNESS FOR A PARTICULAR PURPOSE ARE EXCLUDED. LIABILITY FOR CONSEQUENTIAL DAMAGES UNDER ANY AND ALL WARRANTIES ARE EXCLUDED TO THE EXTENT THAT EXCLUSION IS PERMITTED BY LAW. Some states do not allow limitation on how long an implied warranty lasts, and some

states do not allow the exclusion or limitation or incidental or consequential damages, so the above limitation and exclusion may not apply to you. This warranty gives you specific legal rights and you may also have other rights which may vary from state to state.

E-Z Trench Manufacturing Company, Inc. does not warrant the engine but the purchaser must look to engine manufacturer for the warranty of the engine.

NORMAL WEAR:

Warranty will not cover repair where normal use has exhausted the life of a part. Trenchers, like all mechanical devices, need periodic parts replacement and service to perform well. It should be remembered that the service life of any trencher is dependent on the care it receives and the conditions under which it has to operate. Trenchers operate in harsh conditions, which can cause what appears to be premature wear. Such wear, when caused by rocks or other abrasive material, is not covered by warranty.

E-Z TRENCH WARRANTY DOES NOT COVER ABUSE OR NEGLIGENCE:

1. Bent or broken parts; Such damage is normally the result of abuse, such as striking a solid object with the cutting blade.
2. Broken parts, which results from excessive vibration caused by loose engine mounting, loose cutting blades, unbalanced blades, improperly attaching equipment to trencher, overspeeding or abuse in operation.
3. Misuse, neglect, improper operation, damage or abuse.
4. Alteration or removal of name plates or serial numbers.
5. Modification or change of this product outside the factory.

STANDARD TERMS:

1. C.O.D./F.O.B., Loris, SC, USA
2. Cash, money order, certified check, or wire transfer with order.
3. 30 day with approved credit.

All sales are final with no right to return, price protection or implied consignment. No person, including agent, representative, or employee of E-Z TRENCH MANUFACTURING, Inc. is authorized to assume for E-Z TRENCH MANUFACTURING, Inc. any obligation or liability concerning terms or conditions of sale other than that expressly stated herein.

EFFECTIVE MARCH 1, 1985

